



# November Meeting

11 am Saturday, November 11

Outback Steak House

1509 N. Central Expressway, Plano, TX

Details on page 3



# November 2023 LEGENDS LEDGER

# Upcoming Events 2023

- \*Nov 3-5 **Legends Fredricksburg Trip** Hangar Hotel Fredericksburg, TX
- \*Nov 11 **Legends Club Meeting** Outback Steak House Plano, TX
- \*Dec 2 **Lewisville Christmas Parade** See Map Below Lewisville, TX  
Sponsored by Huffines Auto Dealerships Lewisville. Parade Staging begins at 1:00 pm along Cowan between Parnell & Main. Enter to meet the Corvette Legends at Elm & Edna Streets east of Medical Center of Lewisville. Decorate your car and wear Christmas apparel. Parade starts at 2:00 pm. Bring proof of insurance. Go to lunch together after parade about 2:30 pm at Main Street Cafe, 208 E Main, Lewisville. Contact Diane Preston 405-615-3856 for details.

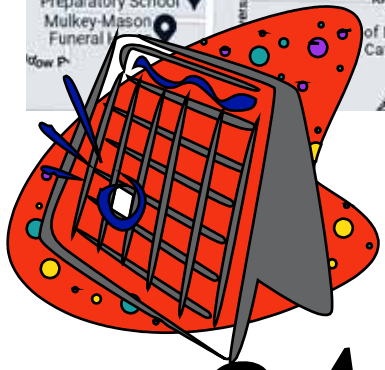

# 2024

- \*Dec 9 **Legends Club Meeting** BJ's Brewhouse & Restaurant Addison, TX
- 2024**-----
- Jan 1 **1st on the 1st Corvette Show** McKinney, TX  
1-3 pm -- Spring Creek BBQ, 1993 N. US 75-Central Expy, McKinney, TX
- \*Jan 13 **Legends After-Holiday Party** TBA
- \*Feb 16-18 **Autorama** Dallas Market Hall Dallas, TX  
Move in on Thurs. Feb. 15. Legends plans to display six C1-C8 Corvettes again this year. Call Tom, if you want yours to be in the show. Tom Hubbert, 972-897-3045 or email thubbert@verizon.net.
- Save the Date!!!**
- \*Aug 29-Sept 2, **2024 National Corvette Caravan to Bowling Green, KY**  
Bill Tichy and Larry Dyer are making plans for Legends to join in the big caravan.

It's time for you to register on line and officially join the Texas Panhandle/Oklahoma Caravan. Search [corvettecaravan.com](http://corvettecaravan.com) and open the caravan registration for the **North Texas tour**. You'll find a form to print and complete. Mail \$25 registration fee for the TX/OK caravan portion of the event to Ed Onley the Captain for our group. Registration for the Bowling Green portion of the Caravan is separate and will become available soon. Give Bill Tichy a call at 972-650-8007 or cell 214-770-6679, if you have any questions or want to let him know you're going to participate with the Legends group. See page 9.

## Birthdays for November



- |                       |                     |                       |
|-----------------------|---------------------|-----------------------|
| 11-06 Stefanie Sammis | 11-13 Jan Manning   | 11-26 Al Macdonald    |
| 11-08 Ron Spurlock    | 11-14 Michael Kmita | 11-27 Annette Sanford |
| 11-08 Mike McCown     | 11-20 Gregg Manning | 11-28 Kim Liptoi      |
| 11-09 Brian Ratcliff  | 11-23 JoAnn Brumit  | 11-29 Jan Koester     |
| 11-10 Donna Wadley    | 11-24 Gary Williams | 11-30 Keith Bessell   |
|                       |                     | 11-30 Keith May       |

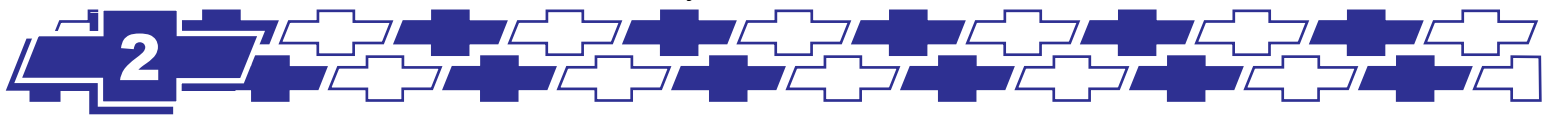

# New Members

**Rob Franklin  
& Caroline Allen**  
Richardson, TX  
2013 Arctic White Coupe



# November Meeting

## 11 am-Saturday, Nov. 11

### Outback Steakhouse

1509 N. Central Expressway  
Plano (972) 392-4600

(West side of US 75 on the north side of 15th St.)



**For Sale!**

**1 of 119  
Produced**

## 1960 Big Brake Corvette

VIN 00867S108636

2 Tops, Roman Red/Ermine White, Black Interior  
283/270 HP, 4-Speed Transmission,  
HD Brakes/Suspension/Special steering, 4:11 Positraction,  
Off Road Exhaust, 15x5.5 Wheels, Heater Delete,  
Numbers Matching. Family owned since 1961.  
No accident history. Multiple Top Flights, Many Spares.

**\$150,000 USD**

**Frank Bibbee, Bedford, TX (817) 707-2004**

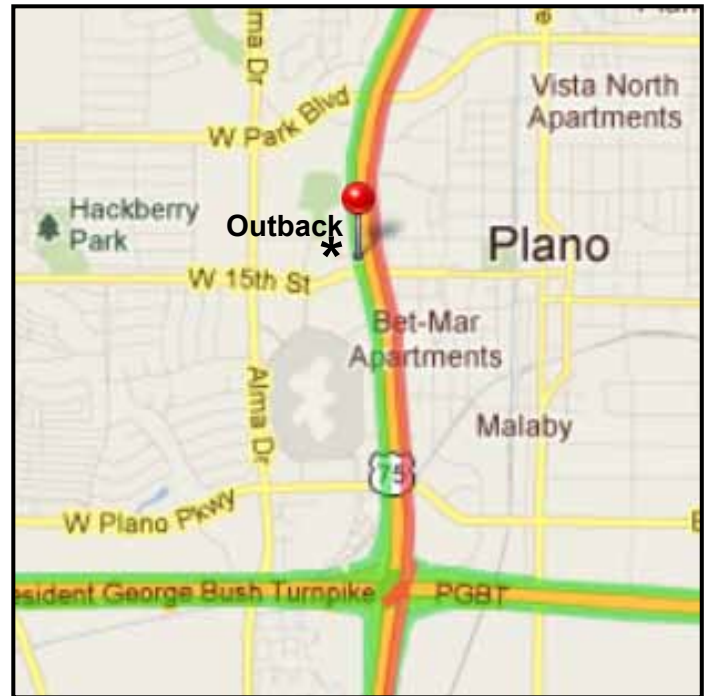

### OFFICERS

President:.....	Sam Deneault.....	sldeneault@gmail.com .....	(214) 546-4677
VP of Operations: .....	Len Woodruff.....	Lenwoodruff@gmail.com .....	(972) 979-5722
VP of Special Events:.....	Tom Hubbert.....	thubbert@verizon.net .....	(972) 897-3045
Secretary:.....	Sharon Conde .....	CockerMom57@gmail.com .....	(972) 658-2526
Treasurer:.....	Kevin Shedden.....	GKevinS@aol.com .....	(214) 502-4721

### DIRECTORS

Director of Communications:.....	Denise Iverson .....	communications@vettelegends.com .....	(214) 684-4649
Weekend Wrench Coordinator:.....	Joel Joseph .....	jjjoseph@yahoo.com .....	(214) 477-6833
Membership Coordinator:.....	Dennis Conte.....	dennis.conte@att.net.....	(972) 839-8473
Newsletter Coordinator:.....	Diane Preston.....	CDiane1957@aol.com .....	(405) 615-3856

*Legends Ledger Newsletter: Published monthly. Send submissions to cdiane1957@aol.com  
Submission deadline is the 15th of the month.*

### Club Web Site:

Coordinated by Denise Iverson <http://www.vettelegends.com>  
Send submissions to: [Communications@VetteLegends.com](mailto:Communications@VetteLegends.com)

### Meeting Speakers:

If you have a recommendation for a guest speaker to address the club at one of our meetings, please contact  
Len Woodruff: [Lenwoodruff@gmail.com](mailto:Lenwoodruff@gmail.com) or (972) 979-5722

### Membership Information:

Coordinated by Dennis Conte (see above)  
\$40 for annual membership  
Dues are paid annually at a meeting or mailed to:

### Club Mailing Address:

Corvette Legends of Texas  
P.O. Box 260316, Plano, TX 75026-0316



# First Drive: Corvette E-Ray, In-Depth with Chief Engineer



## Go on line to see this 47-min. interview about the E-Ray

In this Jay Leno's Garage EXCLUSIVE: Corvette's Executive Chief Engineer Tadge Juechter comes back to the garage bringing with him the very latest and possibly the greatest Corvette ever made; the 2024 Corvette E-Ray! Jay and Tadge go DEEP on the design mechanics of this (hybrid) beast, before they take the E-Ray for a drive. Strap yourselves in, this is truly an episode for the ages!

15 DAY SERVICE	<b>Chrome Plating</b>	15 DAY SERVICE
	<b>15-DAY SERVICE</b>	
	<i>Specializing in</i>	
	<b>CLASSIC CARS</b>	
	<i>- Over 20 Years of Show Quality Plating -</i>	
	<b>Speed &amp; Sport Chrome Plating</b>	
	404 Broadway, Houston, Texas 77012	
	<b>(713) 921-0235 - CRAIG BIERMAN</b>	
	sales@speedsportchrome.com - www.speedsportchrome.com	



*High Quality Restoration, Performance &*

*Maintenance For All Year Models*

TUNE-UPS, ENGINE REPAIR, ELECTRICAL, PERFORMANCE MODS, &  
MORE SERVICES

OUR TEAM IS ASE MASTER CERTIFIED

*WE DON'T JUST WORK ON YOUR  
CORVETTE... WE FIX IT!*

3206 MAIN STREET ROWLETT, TEXAS 75088

972.412.2325

VISIT OUR WEBSITE

[WWW.CORVETTECORNER.NET](http://WWW.CORVETTECORNER.NET)

FOR MORE INFORMATION ABOUT OUR SHOP





















**All original in excellent condition.**

Artic White/Light Oak Interior, 60,200 miles, Original Owners Manual, Clean Carfax, Clear Title, Automatic, Both tops, Heads up display, LS1 5.7L V8, Performance rear axle ratio (3.15), 110 amp alternator, Sport seats, Sport leather steering wheel, Original polished aluminum wheels, AM/FM Radio, Automatic Dual zone AC (cold), Head light retrofit (brass gears), Remote heated mirrors, New Falcon Azenis FK520 tires (factory sizing), New TPWS tire pressure warning system, New NAPA Legend sealed AGM battery.

Love my new C7 so this one has just been sitting. **\$21,500**  
obo, Bob VanGuilder, The Colony TX, 214-957-3692

## Generation Breakout of Legends Members' Corvettes (9/18/2023)

Be sure to let Dennis Conte know when you buy or sell your Corvette(s) so our Corvette census is correct.

		<b>1953</b> <b>1962</b>	30	16%
		<b>1963</b> <b>1967</b>	33	17%
		<b>1968</b> <b>1982</b>	33	17%
		<b>1984</b> <b>1996</b>	11	6%
		<b>1997</b> <b>2004</b>	20	11%
		<b>2005</b> <b>2013</b>	23	12%
		<b>2014</b> <b>2018</b>	28	15%
		<b>2020</b> <b>2024</b>	12	6%
			<hr/>	
			125 Memberships	199 Total



701 Shepherd Drive, Suite 108, Garland, Texas 75042  
(972) 494-6900

**ASE Master Certified**

**30+ Years Experience**

**Specializing in Repair & Restoration**

**Open Monday-Friday  
6:00 to 4:00**

**[DMSCorvetteShop.com](http://DMSCorvetteShop.com)**





*Lady Legends enjoy visiting in the parking lot on the cool October day.*

**CORVETTE LEGENDS OF TEXAS  
GENERAL MEETING October 14, 2023  
Prairie House Restaurant, Lewisville**

The members of Corvette Legends were called to order by President, Sam Deneault, at 12:17 pm. Minutes of the previous meeting were approved. Attendance was 43.

**Guests:** Bob and Marian Carpentier

**Lady Legends Winner:** Sandy Allen

**50/50 Pot Winner:** Jeff Clevenger (\$64)

Dennis Conte said new name tags have been received and the back log of 16 tags were created and mailed to the newest members. Thank you for being patient.

**Nov. 11** meeting-Outback Steakhouse, Plano.

**Dec. 9** meeting-BJs Brewhouse restaurant, Addison.

**Jan.13**-After Holiday party. Plans are in progress.

Tom Hubbert reported that the Good Guys show at Texas Motor Speedway was a fun time though it was hot. The club was represented with 14 cars over the weekend. We had some space so invited a few non-member Corvettes to park with us. Hopefully, we'll gain some new members. Tom Schipper won an award on Sunday. A huge thank you to Tom Hubbert for his efforts organizing the event.

Tom also mentioned that Autorama will be held February 16-18, 2024.

Bill Foote reviewed the final plans for the Fredricksburg trip, November 3-5. There are 17 cars planning to make the trip. The group will meet at Huffines in Lewisville, leaving about 9:30 am on Friday.

Plans for the Corvette Caravan to Bowling Green and the National Corvette Museum 30th anniversary event

next Labor Day weekend continue. Bill Tichy had the sign up sheet and additional info for the registration for the Texas Panhandle/Oklahoma Corvette caravan. Contact Bill for more info. (see pg. 9)

The Southwest Swap meet will be November 3-4 in Arlington, Lot F at Ranger stadium.

Just before we adjourned, Diane asked for a show of hands for interest in the annual Lewisville Christmas parade. It will be on December 2 and it's always a fun time. More info will follow.

The meeting was adjourned at 12:45 pm.

*Submitted by Sharon Conde, Secretary*



*Our parking lot full of Vettes attracted this striking Yellow C8 owner to stop.*



Legends members have enjoyed Barb Macdonald's children's Christian books for the past few years. Now, after five years working on the musical play, "For Such a Time as This, Esther", we've been amazed at her talent and dedication to spreading the word of God.

The musical was presented October

13-14 at the Dupree Theater in the Irving Arts Center. All three performances sold out! We've heard nothing but raves about the play from friends at church and other Legends who attended a performance.



Legends member and playwright Barb Macdonald is pictured above with husband Al Macdonald and Peggy Lee Brennan, who played Queen Vashti.

## Tom Schipper's 2020 Red Coupe Wins Award at Good-Guys



GoodGuys only allows post-1998 vehicles to be displayed on Sunday of the 3-day show. I took my Torch Red 2020 C-8 Corvette to the show and proudly parked in the Corvette Legends display area. While I was away from the display area admiring all the great cars and trucks, Sam Deneault called and told me I had to move my car to the 'Winner's Circle'. I thought Sam and a few of the others were playing a prank on me, but realized when I returned to our Club area that they were

not. I had a notice on the windshield that my car had earned an 'All-American Sunday Award.'

According to GoodGuys media, the award is given to post-1998 American-made and American-powered cars and trucks. I could find no other criteria, except that this award is left to the judges' picks. Most awards are not determined by a strict point system or a committee of judges. Many awards are chosen because the car or truck grabs their attention, and is a very subjective process - that's why they are called picks. I was unable to



talk to anyone that actually judged my car, so I can't give insight as to what made my car stand out - Sorry!

All I did to my car after parking it in the Club display was wipe it down (mostly to get the brake carbon dust off). I used a detailing spray wax on the paint and wheels, and sprayed the tires with tire-black. I opened both trunks and left the windows down. I did not remove the one-piece hardtop or have any signage or literature about the vehicle. I love my car, am very proud to be a member of Corvette Legends, and honored to receive the award. There are many who have put a lot more effort into their cars and deserve this award more than I do.

See page 10 for more on the Good-Guys Show.

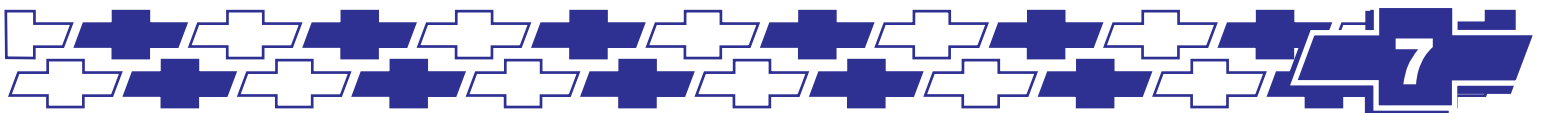

# Don't Break That Window!

## There's a manual door release!

A Florida man was at a gas station in his C7 Corvette convertible and got stuck in his car when the electric door release didn't work. Instead of using the manual door release, he used his cell phone to call the police to get help freeing himself from inside the car. He obviously didn't know about the manual door release located on the floor next to both the driver and passenger doors.

Eventually, Florida firefighters showed up, and before taking extreme measures, they tried to jump the car but broke the passenger window to free the man.

A TikTok video shows the moment a man from Davenport, Florida, had firefighters shatter the passenger window and free the man from the car rather than pull on the manual door release.

Sadly, people don't know that there is a manual override to open the door if the battery dies or there is another electrical issue. This door release is between the seat and the door on the passenger and driver's sides of all Corvettes with electronic doors.

## EVERYTHING for Corvettes & GM Muscle Cars!



**CarrsCorvettesAndCustoms.com**  
**Plano, Texas 972-578-2270**

- C1-C7 Specialists
- Knowledge, Maintenance, Repairs & Restoration
- Engine, Trans, Brakes, Chassis, Exhaust, Suspension, Interior, Fiberglass Repair & Paint
- Factory A/C Repair & Aftermarket Installation
- Power Steering Conversions
- Auto OD and Manual Transmission Conversions
- Multiple National Awards, Magazine Features & Covers
- Resto-Mods, NCRS, Bloomington & Concours

**We do it all...AND do it right the first time!**

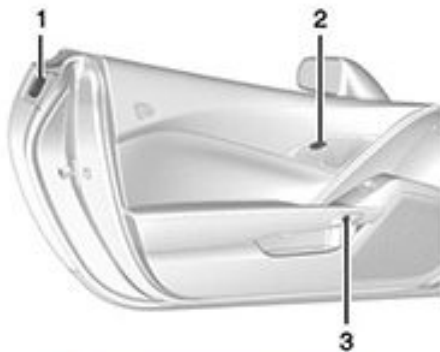

1. Door Handle Sensor
2. Power Door Lock Switch
3. Door Latch Button

For Keyless Access, hold the RKE transmitter within 1 m (3 ft) of the door handle. Grip and press the door handle sensor (1) to open. See *Remote Keyless Entry (RKE) System Operation* ◊ 27. When the passenger door is opened first, the driver door will also unlock. To program this feature, see *Vehicle Personalization* ◊ 134.

To lock or unlock from the inside, use the power door lock switch (2). See *Power Door Locks* ◊ 36.

To open a door from the inside, press the door latch button (3).

### Loss of Vehicle Electrical Power

If the vehicle has lost battery power, open the doors manually.

### From Inside the Vehicle



Pull the driver door release handle.

Page 35 of the  
Corvette Owners Manual



Pull the passenger door release handle.

### From Outside the Vehicle







# Registration Begins Now The 7th National Corvette Caravan August 29-31, 2024

Registration for the activities at Bowling Green Aug. 29-31, 2024 are separate and handled through the National Corvette Museum.

**Come with the Texas Panhandle/Oklahoma Corvette Caravan and travel together to Bowling Green, KY**

Make checks payable and mail to:  
**Ed Onley, TX/OK Caravan Chair**  
4400 Mackenzie Drive  
Moore, OK 73160  
(405) 642-8929

**Mail this form and a \$25 registration fee per car for the tour expenses from Oklahoma to Bowling Green from Aug. 26-28, 2024.**

**Please make checks payable to Ed Onley, TX/OK chair.**

(Deadline for entry is 07/01/2024 set by NCM)

Name: \_\_\_\_\_

Mailing Address: \_\_\_\_\_

City, State, Zip: \_\_\_\_\_

E-Mail: \_\_\_\_\_

Cell Phone(s): \_\_\_\_\_

## OK/TXPanhandle Corvette Caravan Schedule -Monday, August 26, 2024

-Legends Chairmen Bill Tichy & Larry Dyer will lead group from the DFW area Monday morning (time & place TBA)

-Lunch Frontier Chevrolet, El Reno OK on Route 66.

-Route 66 thru Yukon, Bethany, Oklahoma City, Edmond, Wellston. If some want to follow Rt.66 to Tulsa the rest of the caravan will take I-44 to Tulsa. (NTTA tag is good).

-Monday night in Tulsa OK Marriott Southern Hills Resort Hotel. Room rate TBA. (Some folks may want to book reservation at the Hard Rock Casino, but will not be staging there for departure)

## -Tuesday, August 27, 2024

-Depart Marriott Parking Lot. (Early departure time TBA).

-Take I-44 to toll road to Missouri (NTTA Tag is good)

-Stop at Missouri Visitor Center to re-group.

-Lunch at Springfield, MO. (Locations TBA).

-Route 60 East to Cape Girardeau MO. Four caravans meeting there (Hotels TBA). Plans for All-Corvette Car Show, on the Mississippi River in old downtown.

## -Wednesday, August 28, 2024

-Everyone goes to Bowling Green KY, on their own time schedule. Tichy/Dyer will make suggestion for you to make hotel reservation in Bowling Green for our group or make your own reservations now.

**Registration for Events at NCM Aug 29-31, 2024 opens in October 2023. Go to NCM.com**

Need more room for your **VROOM?**

If your passion has taken over your garage, call fellow Corvette Legend Member, Erika Wood-Cherry

She can help you find a home with a larger garage, covered parking or a longer driveway! Don't leave your "baby" out in the cold, CALL TODAY!!

**Ebby**  
HALLIDAY REALTORS®  
EBBY.COM

**For Real Estate results, call Erika!**  
Office: 972/987-3800  
Cell: 214/704-3079  
erikawood@ebby.com

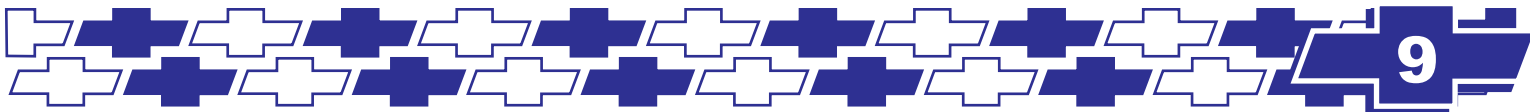

# Legends at Good-Guys Texas Motor Speedway



*Black/White Rochester Fuel-Injected 1957 owned by Bill Preston and John Spencer's Red 1954.*

30th Summit Racing Lone Star Nationals was held the weekend of September 29 - Oct 1, 2023 at Texas Motor Speedway in Fort Worth, Texas. The weather was clear and in the mid-90s, as opposed to the March Good-Guys event that was a rain out. This is a VERY popular event filling the 1.5 mile oval's infield with pre-1998 American cars from all over Texas and neighboring states. Plus the Good-Guys national headquarters has recently moved to TMS. Vendors filled the three NASCAR garages and had Big Rigs in the parking areas. This year there was a very large area full of swap meet entrants and cars for sale.

Of course, there are ALWAYS a lot of Corvettes at this event. Thanks to Tom Hubbert who set the event up for us and was out there all three days. Only American cars 1998 or older were allowed to show on Friday and Saturday. But some of our late-model Corvette owners showed up in their non-Corvette older cars. Bob Rockett had his 1935 Ford pick up there, Dennis Conte brought his 57 Chevy and Dan Jacobs lied about the year his Vette was built... who can tell a 99 from a 98? On Sunday entrants could drive into the show area in any American car, including their brand new 2023 Corvettes!



*Gary Williams returned on Sunday with his Black Rose 2018 Convertible*



*Tom Schipper's Red 2020 Coupe won a prize on Sunday! See page 7*



*Event organizer, Tom Hubbert's Red 1962. Thanks Tom!!!*



*Judy Bailey's 2017 Black Coupe*

*GOOD-GUYS continued on page 11*





Sam & Linda Deneault's 1964 Red Coupe



We invited Corvette owners to park with us. Here's a C3 from Denton. Maybe they will join Legends!



Len Woodruff's 1978 Silver Anniversary

GOOD-GUYS-continued from page10

Legends members gather behind Bob VanGuilder's 1965 White Coupe with the Blue racing stripe to visit and try to cool off.

Mike Kmita's White 1984



Zack Deckich's Red C6 Coupe

Gary Williams brought his 1972 Green Convertible on Saturday



Bob & Linda Rockett came back in their 2020 Red coupe on Sunday with a big FOR SALE sign on it!!!



Jerry Echols Maroon 1966 convertible



**November 11 Meeting**  
Outback Steak House  
Plano, TX  
See page 3

Place  
Postage  
Here



*Proud  
Sponsor  
of Corvette  
Legends*



1400 South Stemmons Freeway  
Lewisville, TX 75067

*We were 30 years young  
when we got our first Corvette...  
How 'bout you?*



**There is NO reason for Corvette  
Legends Club Members to go  
ANYWHERE but Huffines!**

**Call Ted at 972-538-7000  
or Fred at 214-336-8105**

for Special Club Member Prices  
on New and Pre-Owned Vehicles.

Our inventory changes daily,  
and we will work to get the  
vehicle you desire!